

VIEW A

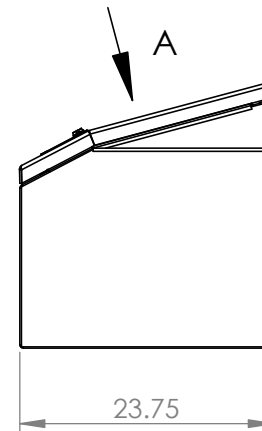
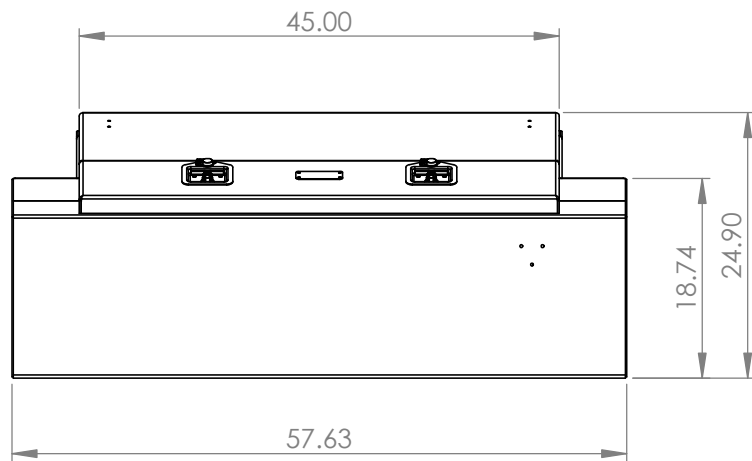

Part No.:

3019

MATERIAL: 5052 (Alum)

Approx. Weight: 77.42 lbs

Surf. Area: 103.36 sq. ft.

THICKNESS: 0.125

ICONIC ELEMENTS

PROPRIETARY AND CONFIDENTIAL
NO PART OF THIS DOCUMENT MAY BE REPRODUCED, STORED IN A RETRIEVAL SYSTEM, OR TRANSMITTED IN ANY FORM, WITHOUT THE WRITTEN PERMISSION OF Iconic Elements Inc.

FINISH: Smooth

TITLE:

Chest Box

DWG. NO.: 4109-0-00-C

REV: SHEET:

C 1 OF 1

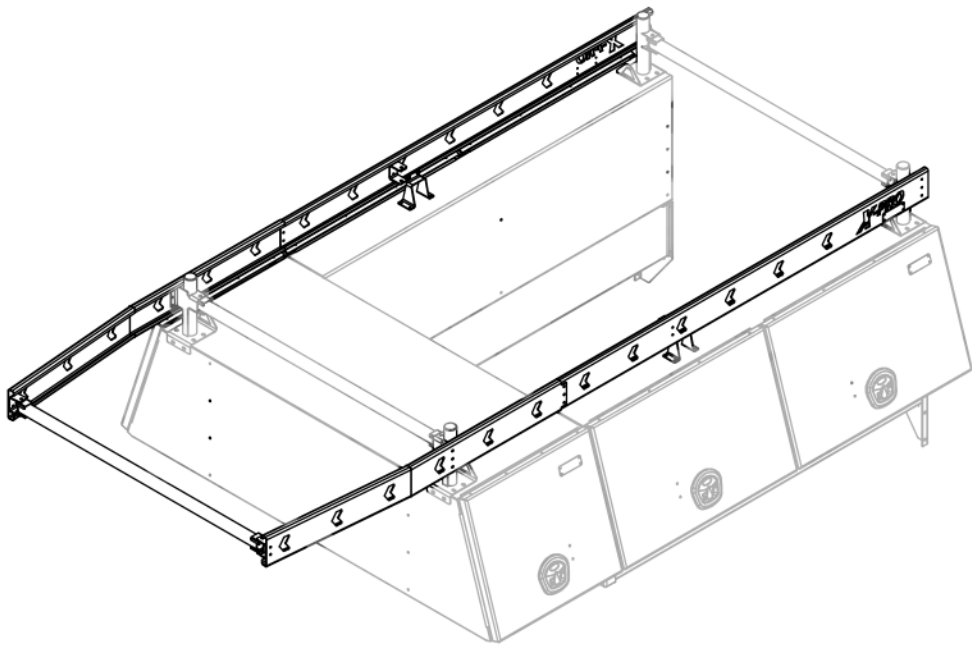
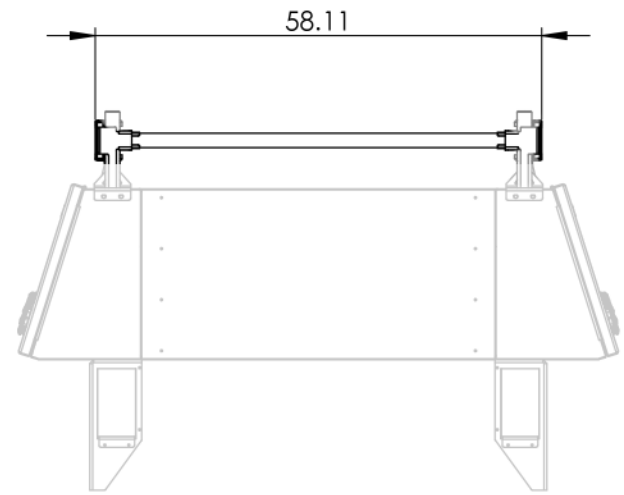
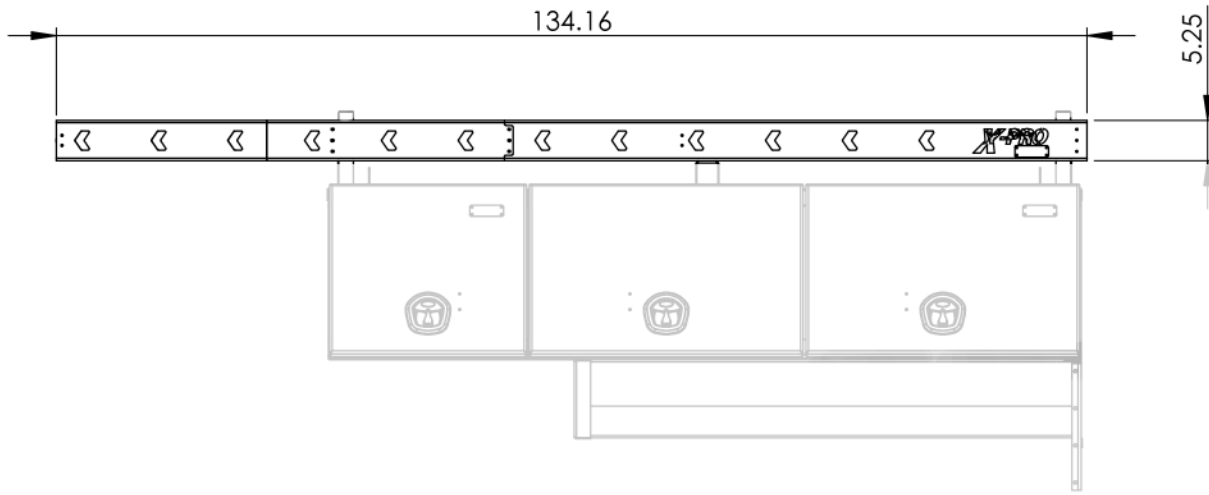

****HARDWARE INCLUDED****

Part No.: 3029	MATERIAL: 5052 (Alum)	THICKNESS: 0.125	FINISH: Smooth	DWG. NO.: 4107-16-00-A
	Approx. Weight: 37.72 lbs	ICONIC ELEMENTS <small>PROPRIETARY AND CONFIDENTIAL NO PART OF THIS DOCUMENT MAY BE REPRODUCED, STORED IN A RETRIEVAL SYSTEM, OR TRANSMITTED IN ANY FORM, WITHOUT THE WRITTEN PERMISSION OF Iconic Elements Inc.</small>		TITLE: Roof Rail - Long
Surf. Area: 34.67 sq. ft.				REV: A SHEET: 1 OF 1

5

4

3

2

1

D
C
B
A

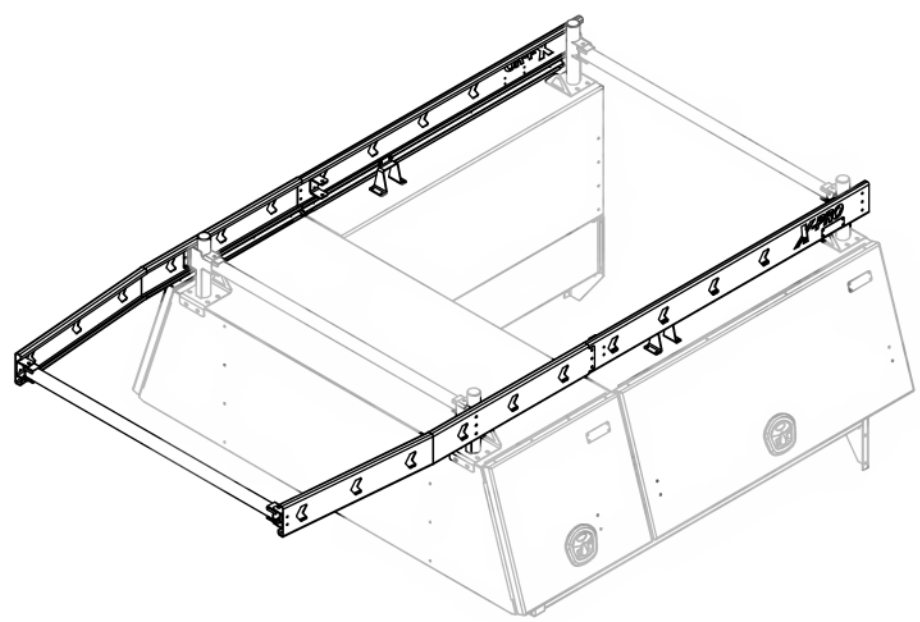
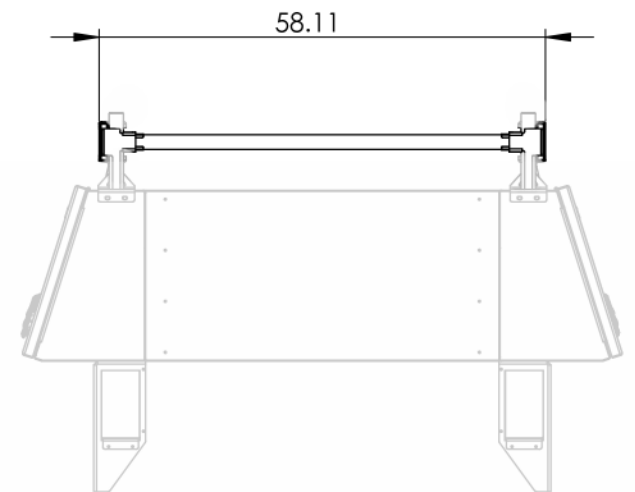
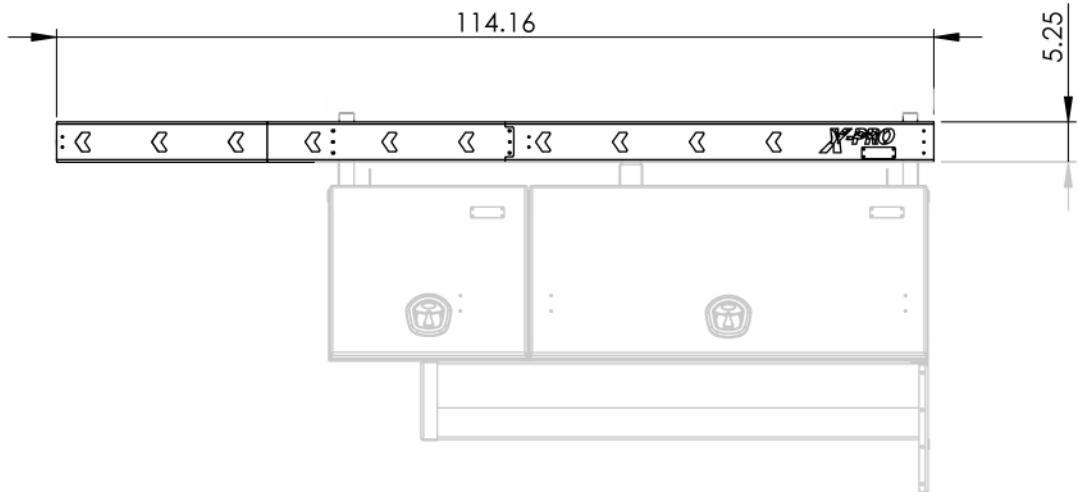

****HARDWARE INCLUDED****

Part No.: 3037	MATERIAL: 5052 (Alum)	THICKNESS: 0.125	FINISH: Smooth	DWG. NO.: 4107-17-00-A
	Approx. Weight: 34.08 lbs	ICONIC ELEMENTS <small>PROPRIETARY AND CONFIDENTIAL NO PART OF THIS DOCUMENT MAY BE REPRODUCED, STORED IN A RETRIEVAL SYSTEM, OR TRANSMITTED IN ANY FORM, WITHOUT THE WRITTEN PERMISSION OF Iconic Elements Inc.</small>		TITLE: Roof Rail - Reg.
Surf. Area: 30.4 sq. ft.				REV: A SHEET: 1 OF 1

5

4

3

2

1

D

C

B

A

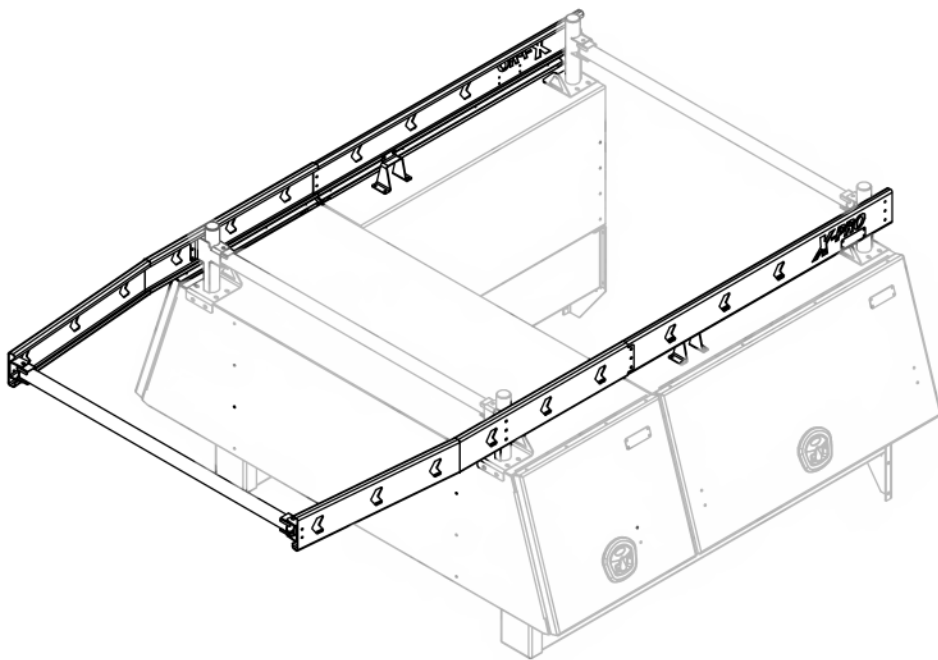
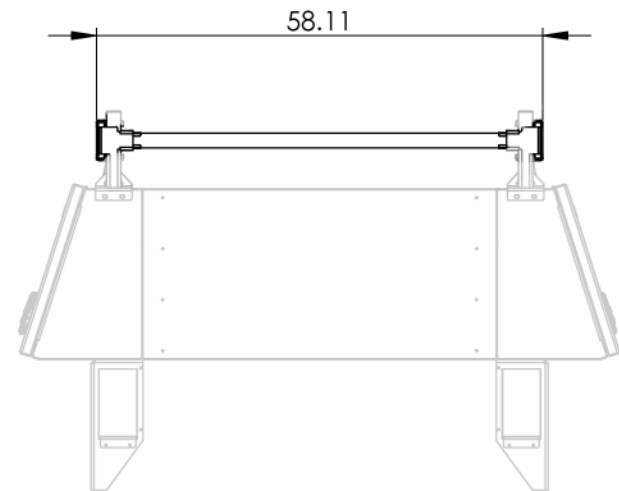
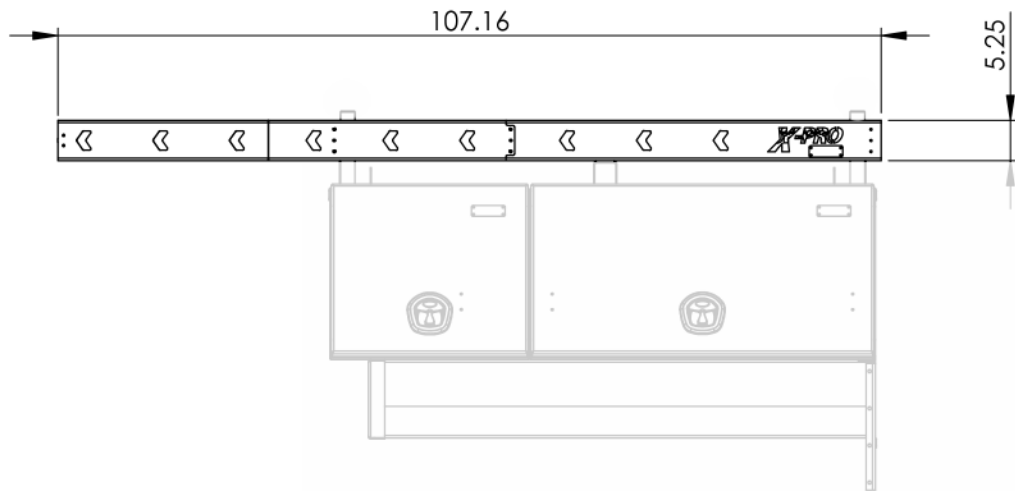

****HARDWARE INCLUDED****

Part No.: 3038	MATERIAL: 5052 (Alum)	THICKNESS: 0.125	FINISH: Smooth	DWG. NO.: 4107-18-00-A
	Approx. Weight: 32.5 lbs	ICONIC ELEMENTS		TITLE: Roof Rail - Short
	Surf. Area: 28.62 sq. ft.	<small>PROPRIETARY AND CONFIDENTIAL NO PART OF THIS DOCUMENT MAY BE REPRODUCED, STORED IN A RETRIEVAL SYSTEM, OR TRANSMITTED IN ANY FORM, WITHOUT THE WRITTEN PERMISSION OF Iconic Elements Inc.</small>		REV: A
				SHEET: 1 OF 1

5

4

3

2

1

D

C

B

A

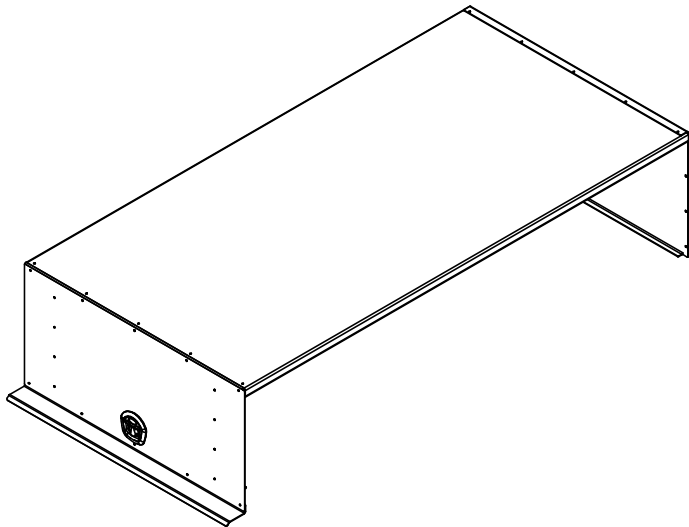
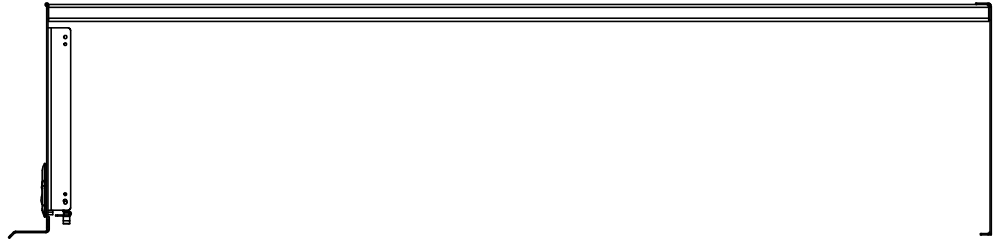
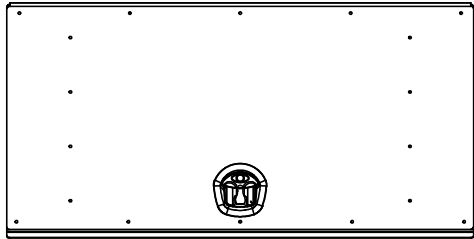

D

C

B

A

Part No.:

3034

MATERIAL: 5052 (Alum)

THICKNESS: 0.125

FINISH: Smooth

DWG. NO.: 4107-10-00-A

Approx. Weight: 101.21 lbs

ICONIC ELEMENTS

TITLE:

REV: SHEET:

Surf. Area: 120.09 sq. ft.

PROPRIETARY AND CONFIDENTIAL
NO PART OF THIS DOCUMENT MAY BE REPRODUCED, STORED IN A RETRIEVAL SYSTEM, OR TRANSMITTED IN ANY FORM, WITHOUT THE WRITTEN PERMISSION OF Iconic Elements Inc.

Roof Assy - Long

A 1 OF 1

5

4

3

2

1

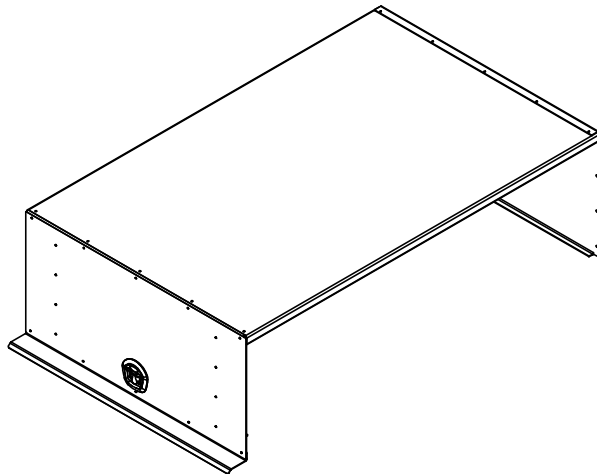
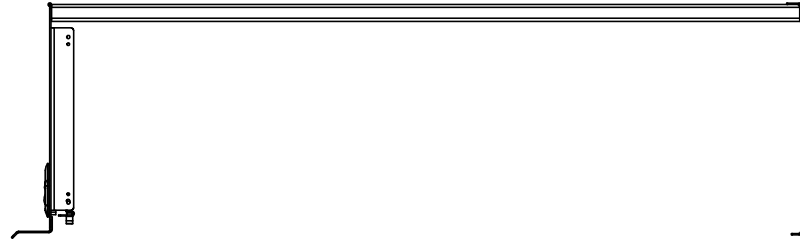
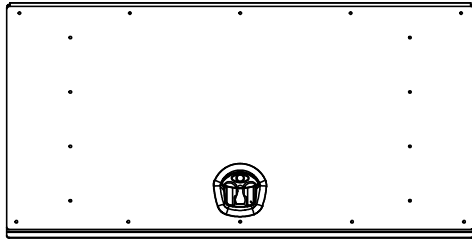

****HARDWARE INCLUDED****

Part No.: 3035	MATERIAL: 5052 (Alum)	THICKNESS: 0.125	FINISH: Smooth	DWG. NO.: 4107-11-00-A
	Approx. Weight: 88.15 lbs	ICONIC ELEMENTS <small>PROPRIETARY AND CONFIDENTIAL NO PART OF THIS DOCUMENT MAY BE REPRODUCED, STORED IN A RETRIEVAL SYSTEM, OR TRANSMITTED IN ANY FORM, WITHOUT THE WRITTEN PERMISSION OF Iconic Elements Inc.</small>		REV: SHEET:
	Surf. Area: 105.07 sq. ft.	TITLE: Roof Assy - Reg.		A 1 OF 1

5

4

3

2

1

D

C

B

A

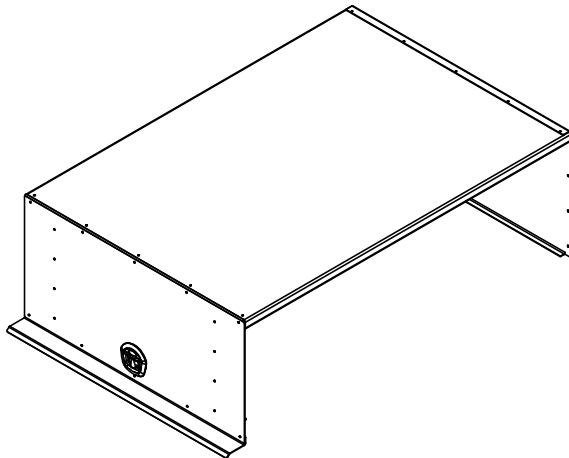
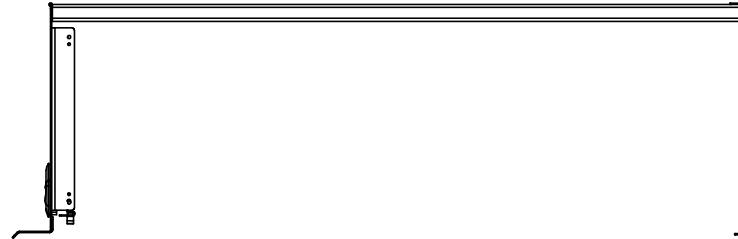
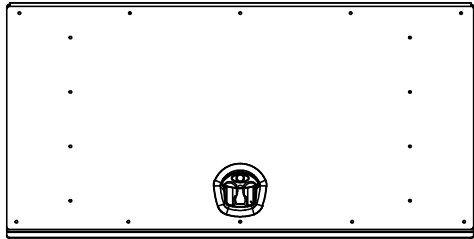

****HARDWARE INCLUDED****

Part No.: 3036	MATERIAL: 5052 (Alum)	THICKNESS: 0.125	FINISH: Smooth	DWG. NO.: 4107-12-00-A
	Approx. Weight: 84.23 lbs	ICONIC ELEMENTS <small>PROPRIETARY AND CONFIDENTIAL</small>		REV: A
	Surf. Area: 100.57 sq. ft.	<small>NO PART OF THIS DOCUMENT MAY BE REPRODUCED, STORED IN A RETRIEVAL SYSTEM, OR TRANSMITTED IN ANY FORM, WITHOUT THE WRITTEN PERMISSION OF Iconic Elements Inc.</small>		SHEET: 1 OF 1

5

4

3

2

1

D

C

B

A

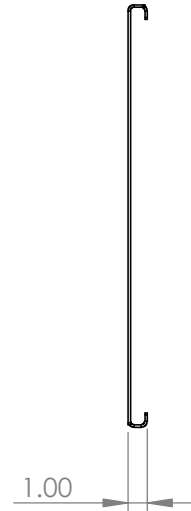
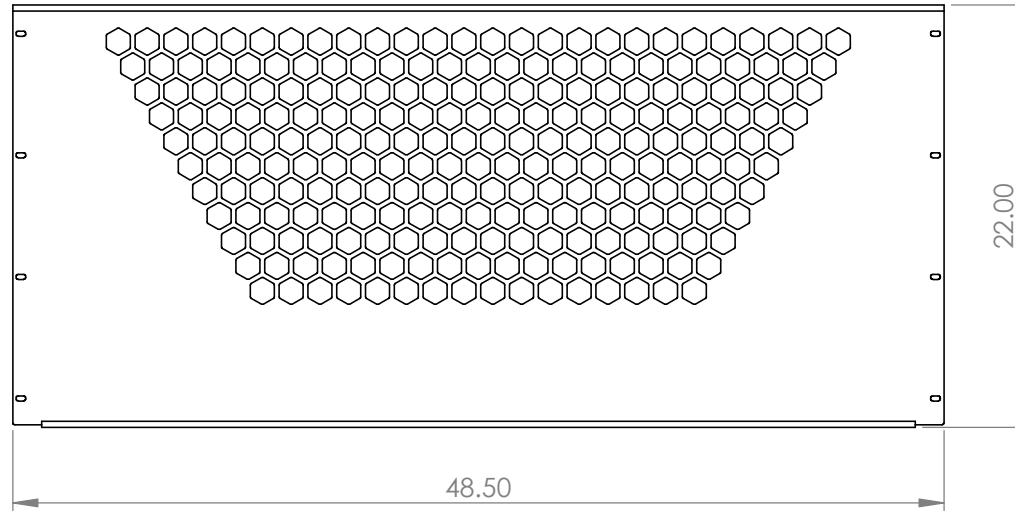
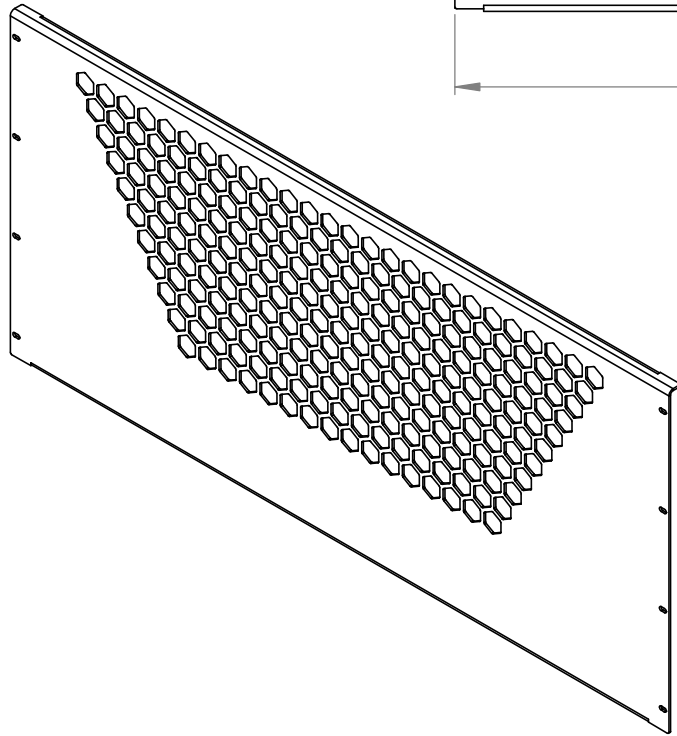

D
C
B
A

Part No.:	MATERIAL: 5052 (Alu)	THICKNESS: 0.125	FINISH: Smooth	DWG. NO.: 4107-03-01-A
3025	Approx. Weight: 10.56 lbs	ICONIC ELEMENTS		REV: SHEET:
	Surf. Area: 13.11 sq. ft.	<small>PROPRIETARY AND CONFIDENTIAL NO PART OF THIS DOCUMENT MAY BE REPRODUCED, STORED IN A RETRIEVAL SYSTEM, OR TRANSMITTED IN ANY FORM, WITHOUT THE WRITTEN PERMISSION OF Iconic Elements Inc.</small>		A 1 OF 1
			TITLE: Window Screen	

5

4

3

2

1

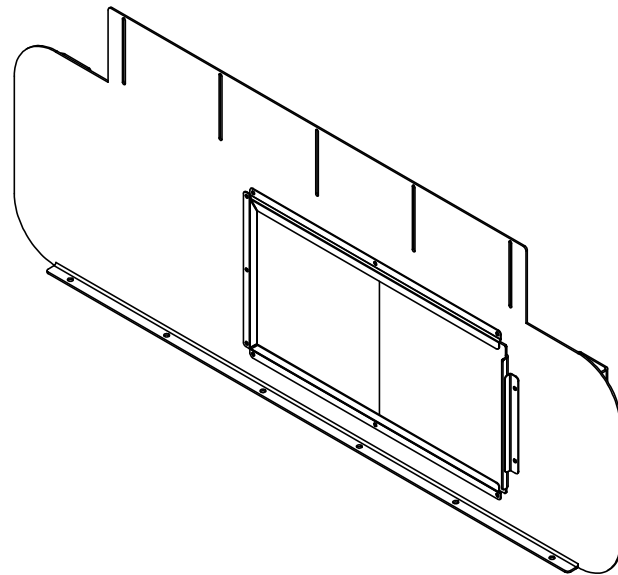
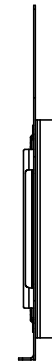
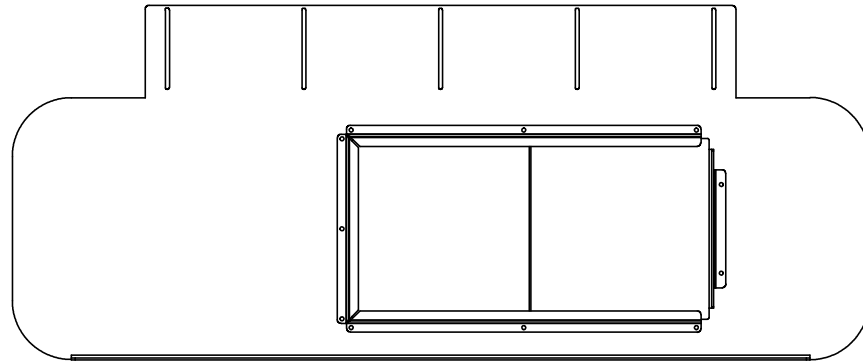

****HARDWARE INCLUDED****

Part No.: 3030	MATERIAL: 5052 (Alum) Approx. Weight: 22.12 lbs Surf. Area: 25.91 sq. ft.	THICKNESS: 0.125 ICONIC ELEMENTS <small>PROPRIETARY AND CONFIDENTIAL NO PART OF THIS DOCUMENT MAY BE REPRODUCED, STORED IN A RETRIEVAL SYSTEM, OR TRANSMITTED IN ANY FORM, WITHOUT THE WRITTEN PERMISSION OF Iconic Elements Inc.</small>	FINISH: Smooth TITLE: Propane Cover	DWG. NO.: 4107-01-00-A REV: A	SHEET: 1 OF 1
--------------------------	---	---	---	----------------------------------	---------------

5

4

3

2

1

D

C

B

A

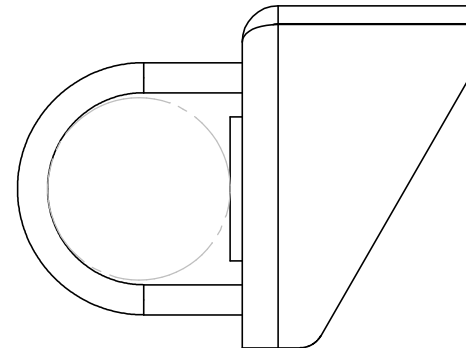
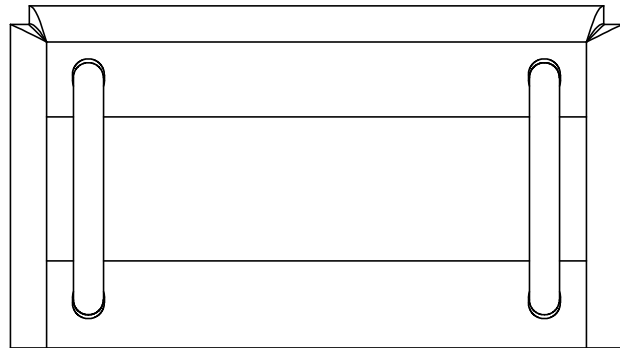
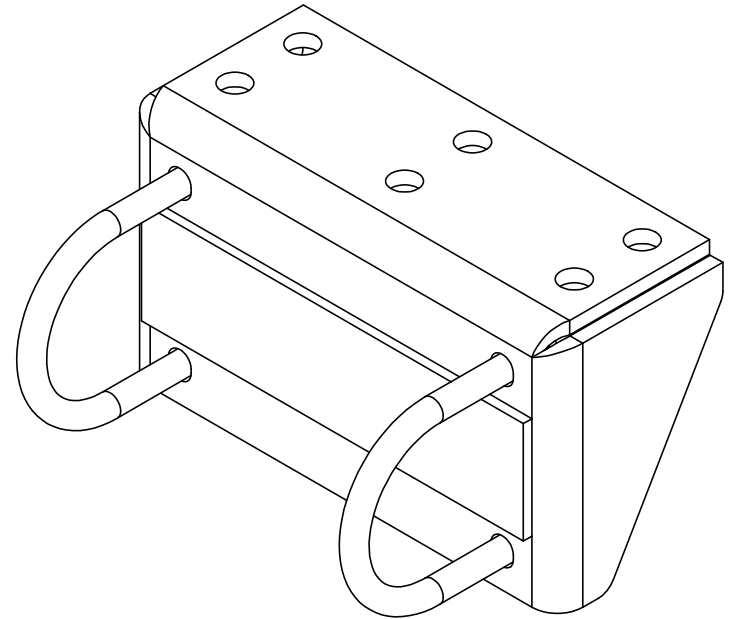
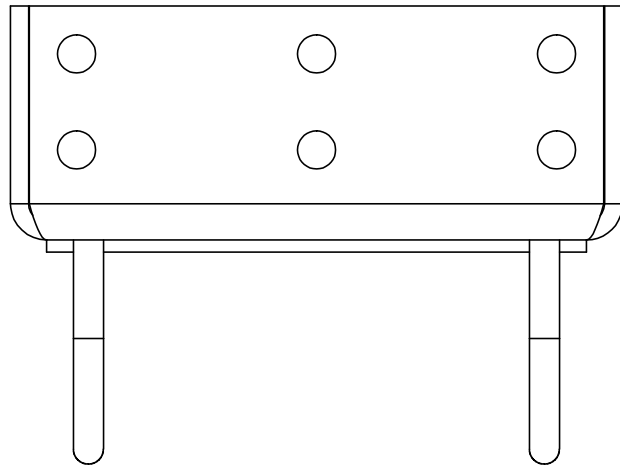

****HARDWARE INCLUDED****

Part No.: 3014	MATERIAL: 5052 (Alum) Approx. Weight: 1.14 lbs Surf. Area: 0.92 sq. ft.	THICKNESS: 0.188 ICONIC ELEMENTS <small>PROPRIETARY AND CONFIDENTIAL NO PART OF THIS DOCUMENT MAY BE REPRODUCED, STORED IN A RETRIEVAL SYSTEM, OR TRANSMITTED IN ANY FORM, WITHOUT THE WRITTEN PERMISSION OF Iconic Elements Inc.</small>	FINISH: Smooth TITLE: Crossbar Acc Mount	DWG. NO.: 4021-05-00-A REV: A	SHEET: 1 OF 1
--------------------------	---	---	--	----------------------------------	------------------

5

4

3

2

1

D

C

B

A

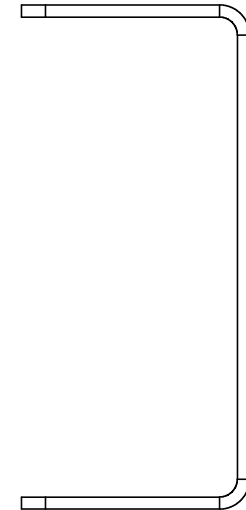
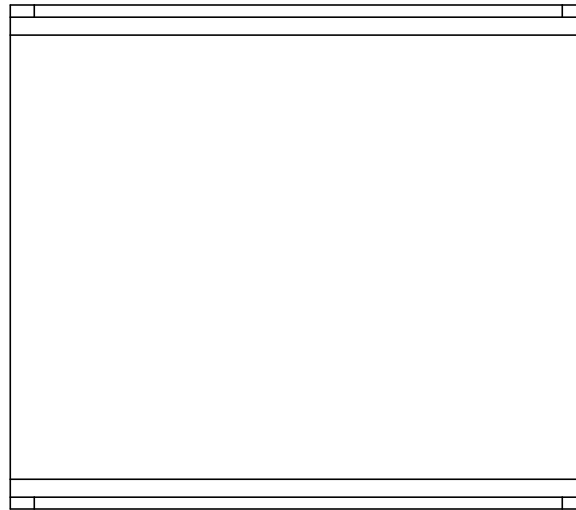
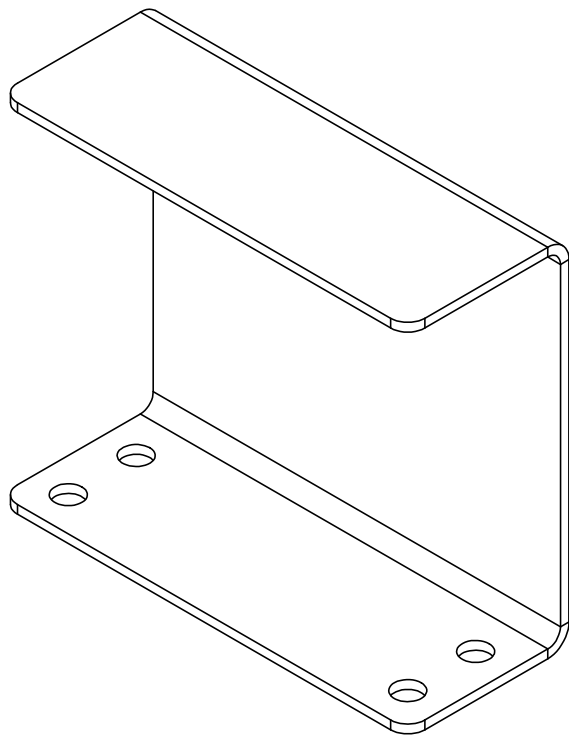

****HARDWARE INCLUDED****

Part No.: 3015	MATERIAL: 5052 (Alu) Approx. Weight: 0.69 lbs Surf. Area: 0.82 sq. ft.	THICKNESS: 0.125 ICONIC ELEMENTS <small>PROPRIETARY AND CONFIDENTIAL NO PART OF THIS DOCUMENT MAY BE REPRODUCED, STORED IN A RETRIEVAL SYSTEM, OR TRANSMITTED IN ANY FORM, WITHOUT THE WRITTEN PERMISSION OF Iconic Elements Inc.</small>	FINISH: Smooth TITLE: Ladder Stop	DWG. NO.: 4021-06-01-A REV: A SHEET: 1 OF 1
--------------------------	--	---	---	---

5

4

3

2

1

D

C

B

A

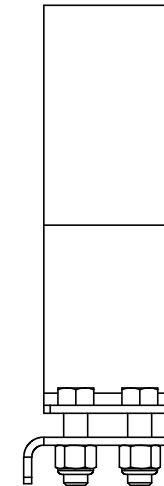
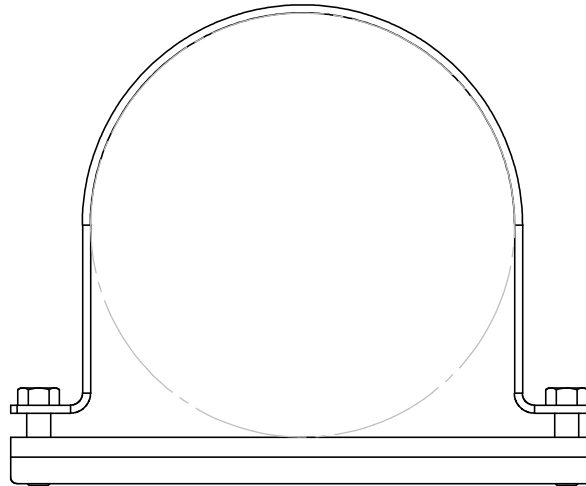
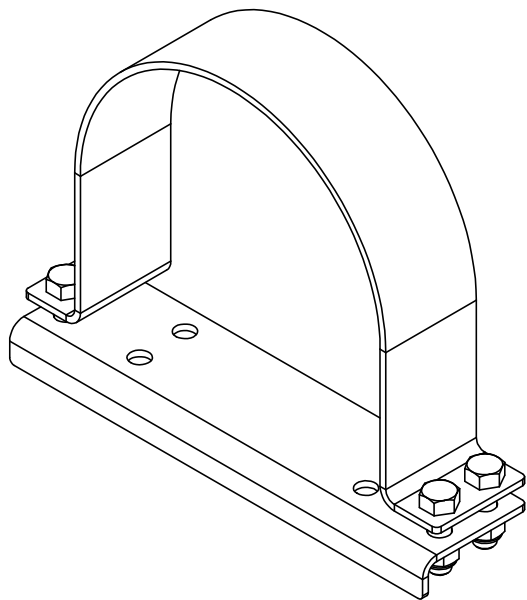

****MUST BE ORDERED WITH P/N: 3014 TO MOUNT****

****HARDWARE INCLUDED****

Part No.: 3016	MATERIAL: 5052 (Alum) Approx. Weight: 0.78 lbs Surf. Area: 1.03 sq. ft.	THICKNESS: 0.125 ICONIC ELEMENTS <small>PROPRIETARY AND CONFIDENTIAL NO PART OF THIS DOCUMENT MAY BE REPRODUCED, STORED IN A RETRIEVAL SYSTEM, OR TRANSMITTED IN ANY FORM, WITHOUT THE WRITTEN PERMISSION OF Iconic Elements Inc.</small>	FINISH: Smooth TITLE: Pipe Clamp	DWG. NO.: 4107-09-00-A REV: A	SHEET: 1 OF 1
--------------------------	---	---	--	----------------------------------	------------------

5

4

3

2

1

D

C

B

A

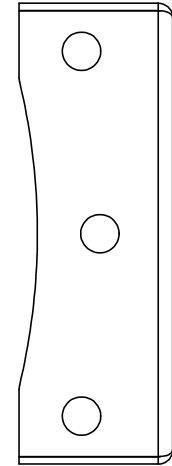
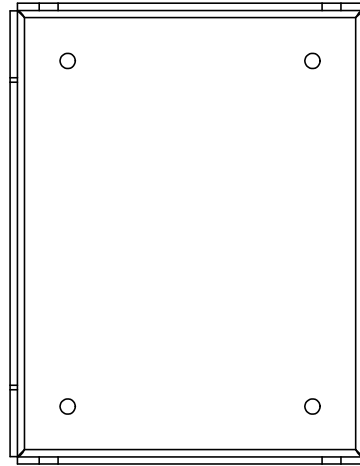
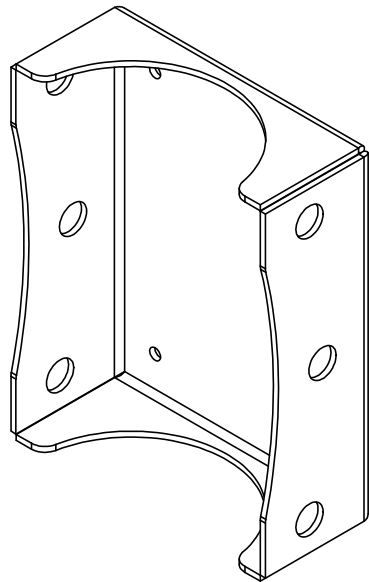

****HARDWARE INCLUDED****

Part No.:	MATERIAL: 5052 (Alu)	THICKNESS: 0.188	FINISH: Smooth	DWG. NO.: 4107-04-01-A
3031	Approx. Weight: 3.97 lbs Surf. Area: 3.18 sq. ft.	ICONIC ELEMENTS <small>PROPRIETARY AND CONFIDENTIAL NO PART OF THIS DOCUMENT MAY BE REPRODUCED, STORED IN A RETRIEVAL SYSTEM, OR TRANSMITTED IN ANY FORM, WITHOUT THE WRITTEN PERMISSION OF Iconic Elements Inc.</small>		TITLE: Tank Bracket
REV: A	SHEET: 1 OF 1	5	4	3

5

4

3

2

1

D

C

B

A

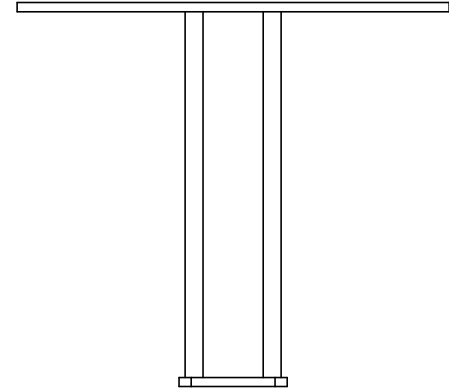
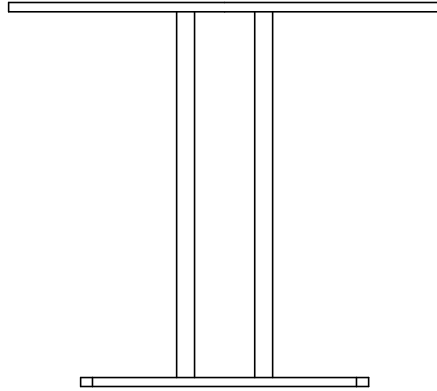
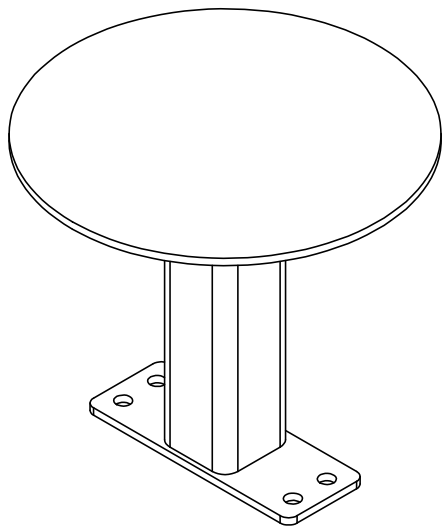

****HARDWARE INCLUDED****

Part No.: 3032	MATERIAL: 5052 (Alum) Approx. Weight: 2.04 lbs Surf. Area: 1.88 sq. ft.	THICKNESS: 0.188 ICONIC ELEMENTS <small>PROPRIETARY AND CONFIDENTIAL NO PART OF THIS DOCUMENT MAY BE REPRODUCED, STORED IN A RETRIEVAL SYSTEM, OR TRANSMITTED IN ANY FORM, WITHOUT THE WRITTEN PERMISSION OF Iconic Elements Inc.</small>	FINISH: Smooth TITLE: 8" Round Emerg. Light	DWG. NO.: 4107-08-00-A REV: A	SHEET: 1 OF 1
--------------------------	---	---	---	----------------------------------	------------------

5

4

3

2

1

D

C

B

A

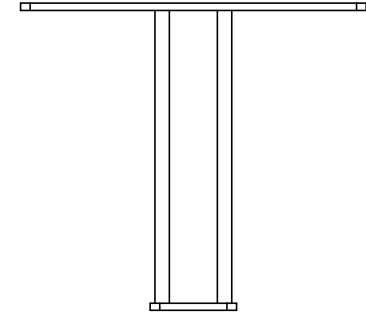
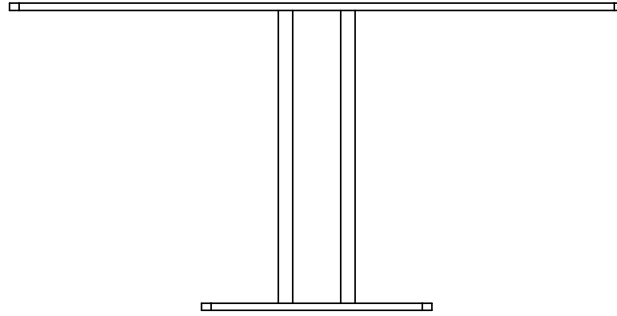
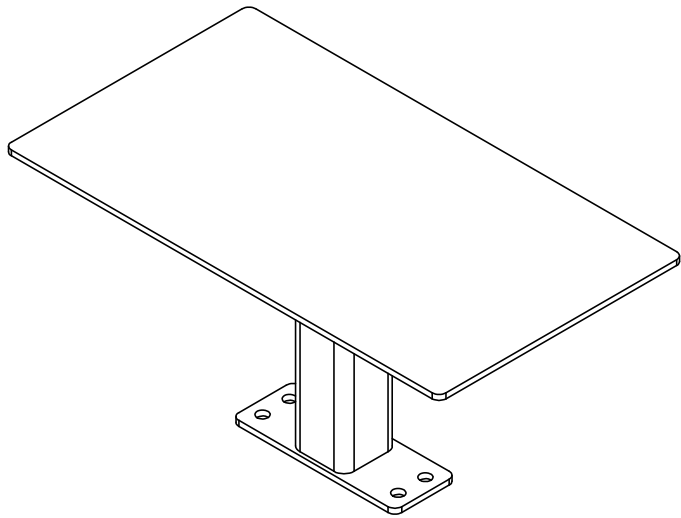

****HARDWARE INCLUDED****

Part No.: 3033	MATERIAL: 5052 (Alum) Approx. Weight: 3.50 lbs Surf. Area: 3.02 sq. ft.	THICKNESS: 0.188 ICONIC ELEMENTS <small>PROPRIETARY AND CONFIDENTIAL NO PART OF THIS DOCUMENT MAY BE REPRODUCED, STORED IN A RETRIEVAL SYSTEM, OR TRANSMITTED IN ANY FORM, WITHOUT THE WRITTEN PERMISSION OF Iconic Elements Inc.</small>	FINISH: Smooth TITLE: 9" x 16" Rec. Emerg. Light	DWG. NO.: 4107-07-00-A REV: A	SHEET: 1 OF 1
--------------------------	---	---	--	----------------------------------	---------------

5

4

3

2

1

D

C

B

A